

SKJB/SKJBS

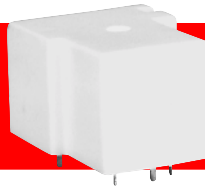

SKJBS



SKJB

SKJB

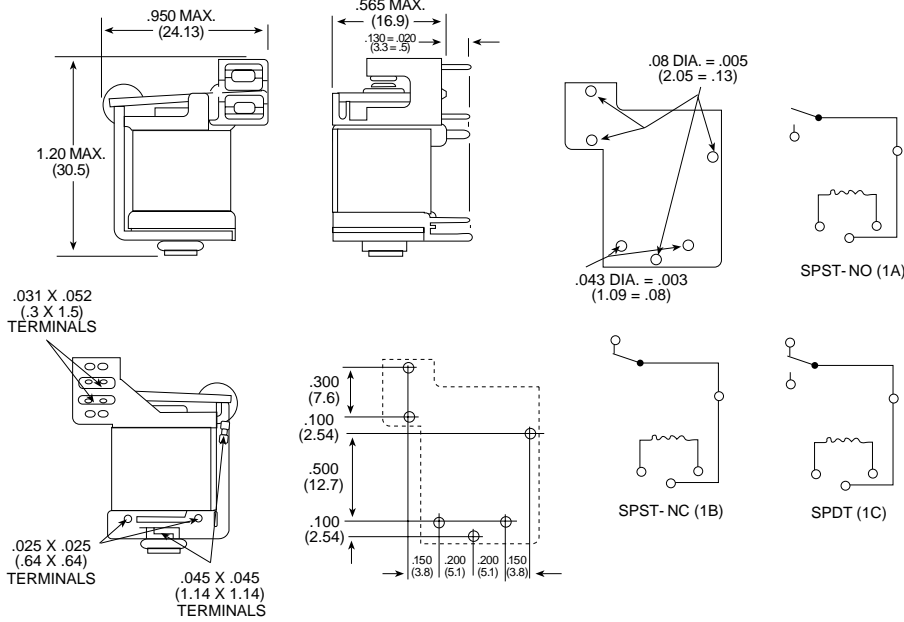

Reference Data

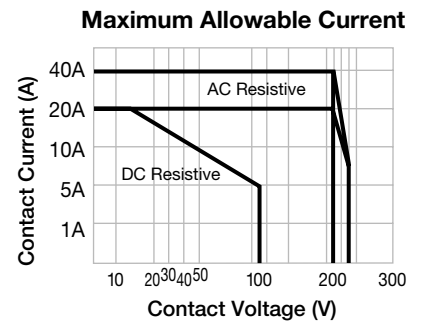
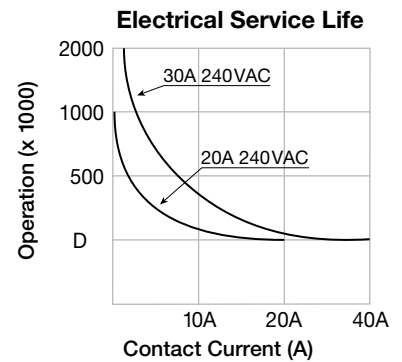
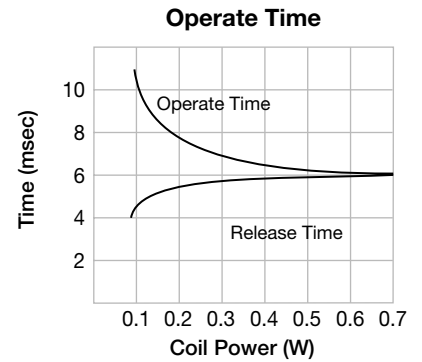
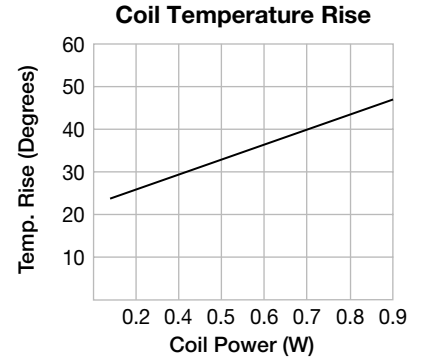

SKJBS

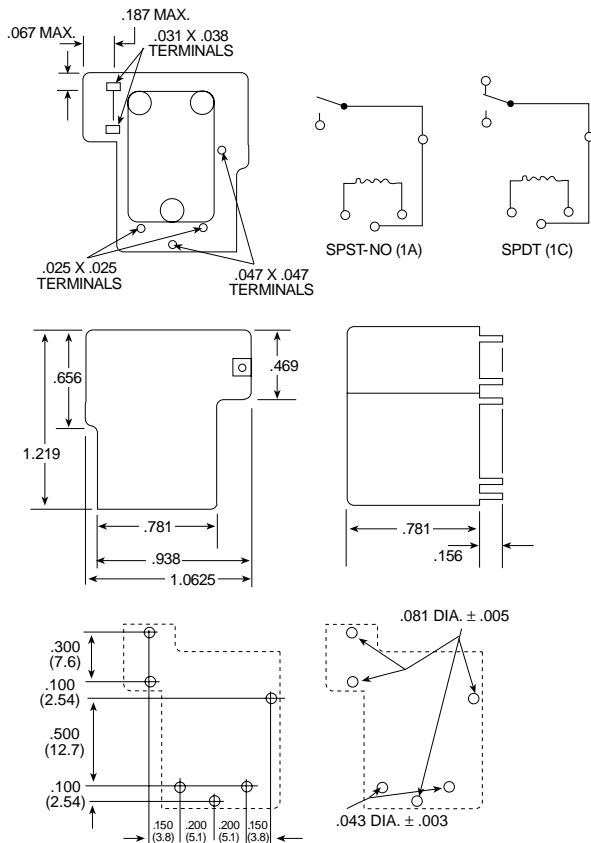

Performance (At Initial Value)

ITEM	TYPE
	SKJB/SKJBS
Contact Resistance	50 mΩ Max.
Operate Time	120 msec Max.
Release Time	8 msec Max.
Dielectric Strength: Between Coil and Contact Between Contacts	2500 V, 50 Hz 1500 V, 50 Hz
Surge Resistance	1000 V (between coil and contacts 1x40 μ sec.)
Insulation Resistance	1000 MΩ Min. (500 VDC)
Max. ON/OFF Switching: Mechanically Electrically	300 operations/min. 30 operations/min.
Operating Ambient Temperature	-55°C to +125°C (no water condensation and no water drop)
Operating Humidity	85% at 40°C
Coil Temperature Rise	UL Specs
Vibration: Endurance Error Operation	10 to 55 Hz Dual Amplitude 1.5 mm 10 to 55 Hz Dual Amplitude 1.5 mm
Shock: Endurance Error Operation	20 G Min. 10 G Min.
Life Expectancy: Mechanically Electrically	10 ⁷ operations/min. (no load) 10 ⁵ operations/min. (at rated coil voltage)
Weight	27 grams open, 30 grams sealed

**SKJB
SKJBS**

Coil Specification (At 20°C)

TYPE	Rated Voltage (VDC)	Coil Resistance (Ω) ±10%	Must Operate Voltage (VDC) (Max)	Must Release Voltage (VDC) (Min)	Maximum Voltage (VDC)	Coil Power (W)
SKJB/SKJBS	3	10	2.25	0.3	130% of Rated Voltage	0.9
	5	28	3.75	0.5		
	6	40	4.50	0.6		
	9	90	6.75	0.9		
	12	160	9.00	1.2		
	15	250	10.25	1.5		
	18	360	13.50	1.8		
	24	640	18.00	2.4		
48	2560	36.00	4.8			

AC Coil Specification

Rated Voltage (VAC)	Coil Resistance (Ω) ±10%	Coil Power (W)
12	15.6	2VA
24	31.2	
110	143	
120	156	
220	286	

Contact Rating

ITEM	TYPE
	SKJB/SKJBS
Contact Capacity Resistive Load (Cos. φ = 1) Inductive Load (Cos. φ = 0.4 L/R = 7 msec.)	NO: 30A 240VAC, 14VDC; NC: 20A 240VAC, 30A 14VDC; NO: 40A 250VAC, 30VDC; NC: 30A 250VAC, 30VDC; NO: 30A 277VAC; NC: 20A 277VAC
Rated Carrying Current	30 A, SKJB / 40 A, SKJBS
Max. Allowable Voltage	DC 110 V, AC 277 V
Max. Allowable Current	900 W, 7200VAC
Contact Material	AgSnO ₂

Ordering Information

SKJB 1C 12VDC

Coil Voltage
See coil specifications for available voltages. Other voltages available as special orders.

Contact Configuration
1A, 1B, 1C

B – Open Frame
BS – Sealed

UL #E96834(M) (U.S. & Canada)

